

Oxx Power™ Industrial Engines

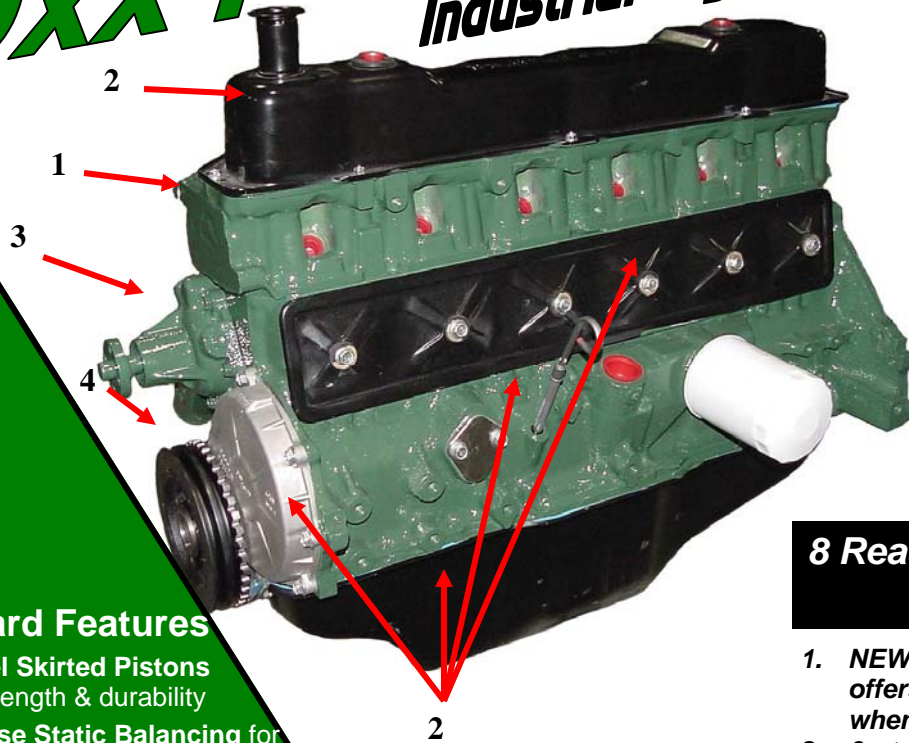

HEC649I-CLB 4.9L 6-Cylinder NEW Long Block Industrial Engine



8 Reasons to choose HEC as your source for power

1. **NEW Oxx Power block and cylinder head offers increased strength and durability when compared with the OEM version.**
2. **6-qt. Center sump industrial oil pan, timing cover, side cover, rocker cover, dipstick & tube.**
3. **Hi-Capacity water pump**
4. **2-Groove balancer**
5. **Heavy-Duty shipping crate**
6. **Corrosion resistant Oxide finish**
7. **Dyno tested to ensure performance and quality**
8. **3 Year or 3000 Hour Warranty**

Standard Features

- **Barrel Skirted Pistons** for strength & durability
- **Precise Static Balancing** for smooth operation & durability
- **Custom Ground Cam** for improved low speed torque & power
- **Decked Cast Iron Cylinder Block** with Seven Main Bearing Journals for superior strength & durability
- **Full Length Water Jackets** surrounding each cylinder
- **Decked Alloy Cast Iron Cylinder Head** for long maintenance free operation
- **High Flow Water Pump** for optimum coolant flow
- **All Engine Sheet Metal** included
- **All Engines are Dyno Tested** over the entire RPM range to guarantee proper function before oil is drained prior to shipping

Typical Power Ratings

Rated Power @ 3600 RPM Intermittent: 125 HP (93 kW)
 Continuous: 102 HP (75 kW)
 Peak Torque @ 2000 RPM Intermittent: 242 Ft. Lbs. (328 Nm)
 Continuous: 205 Ft. Lbs. (277 Nm)

Specifications

Engine Type..... Inline 6-cyl
 Bore & Stroke 4.03" X 3.98" (102.1 X 101.1mm)
 Displacement..... 4.9L (300 CID)
 Compression Ratio 9.0:1
 Oil Capacity 7 qts. (6.6 liters) including filter
 Net Weight..... 437 lbs. (215 kgs.)
 Fuel..... Gasoline, 87 A.K.I.
 Optional use ofLPG, NG & other fuel blends

Specifications subject to change without notice.

Hydrogen Engine Center, Inc.

2502 E Poplar St, Algona, IA 50511
 Tel: 515-295-3178, Fax: 515-395-1877
 Sales@hydrogenenginecenter.com

By

HEC

Hydrogen Engine Center **HEC**

Long Block Dimensions

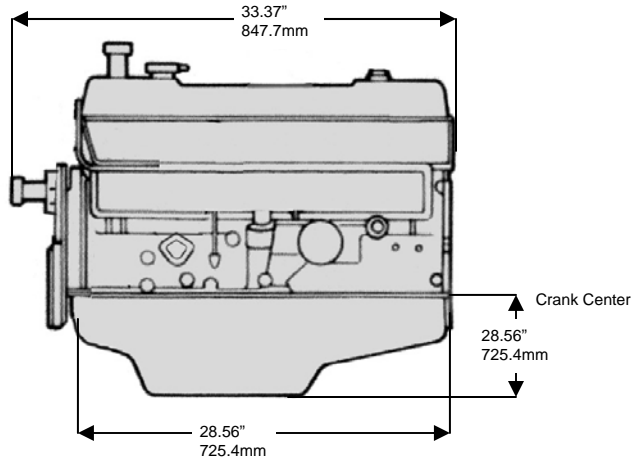
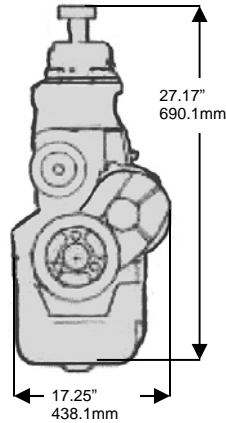

Power Curves

Corrected per SAE J1995

■ Intermittent BHP
■ Continuous BHP

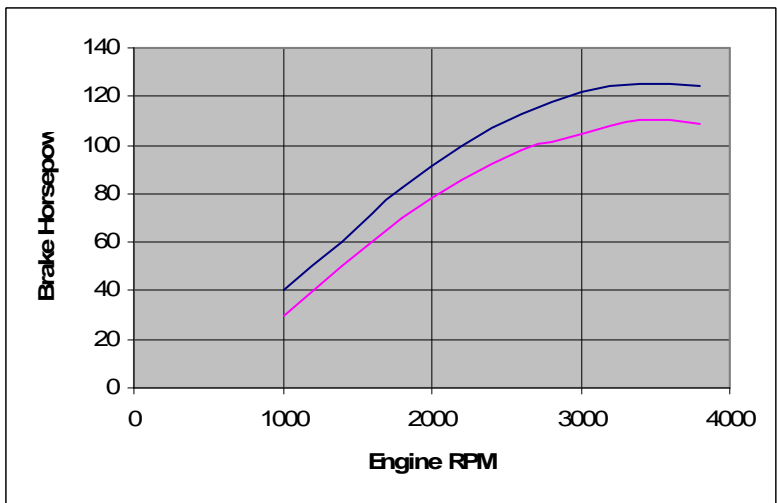

Typical Power Curves

Actual power will depend upon fuel system used and engine tuning

■ Intermittent Torque
■ Continuous Torque

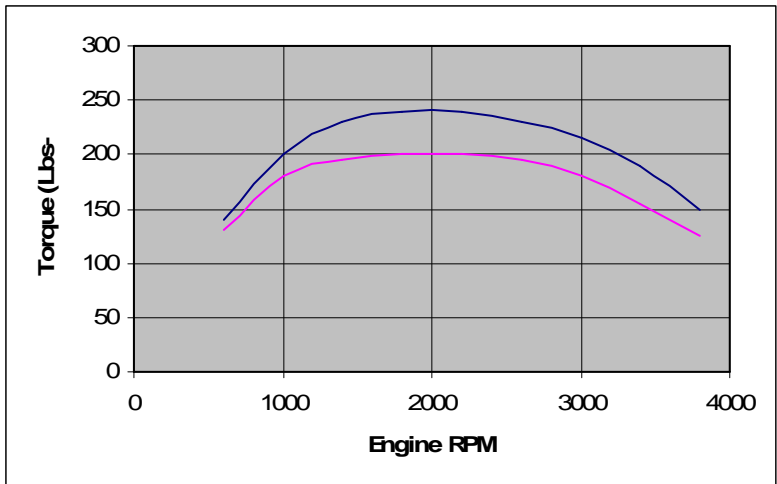

Hydrogen Engine Center, Inc.
2502 E Poplar St, Algona, IA 50511
Tel: 515-295-3178, Fax: 515-395-1877
Sales@hydrogenenginecenter.com

